

Modulated Electroluminescence for Minority-Carrier Relaxation in HJ-Si and CIGS Cells (PVCORE-2)



A joint India-U.S. research consortium funded under the *Joint Clean Energy Research & Development Center (JCERDC)*

Scientific Achievement:

Relaxation time of minority carriers in solar cells is obtained from the frequency dependence of inphase (A_{in}) and quadrature (A_{quad}) components of modulated electroluminescence (MEL) using standard electrical equipment.

Significance and Impact:

In MEL, the relaxation time is obtained from the frequency at which the quadrature component peaks, independent of a knowledge of material parameters such as mobility. Hence, it can be used for any finished cell that has detectable light emission.

Research Details:

- For silicon solar cells, the relaxation is dominated by recombination and the relaxation time is the minority-carrier lifetime.
- In contrast, for the CIGS solar cells, the relaxation time is dominated by trapping and emission from shallow minority-carrier traps.

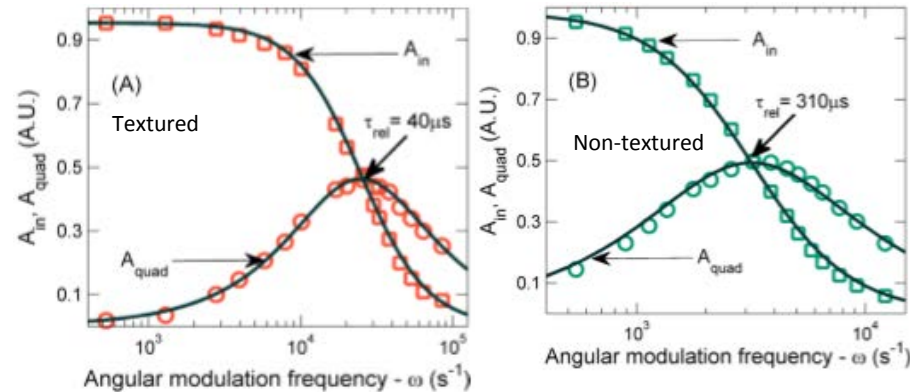

Fig. 1: MEL response of a textured and non-textured HJ-Si solar cell.

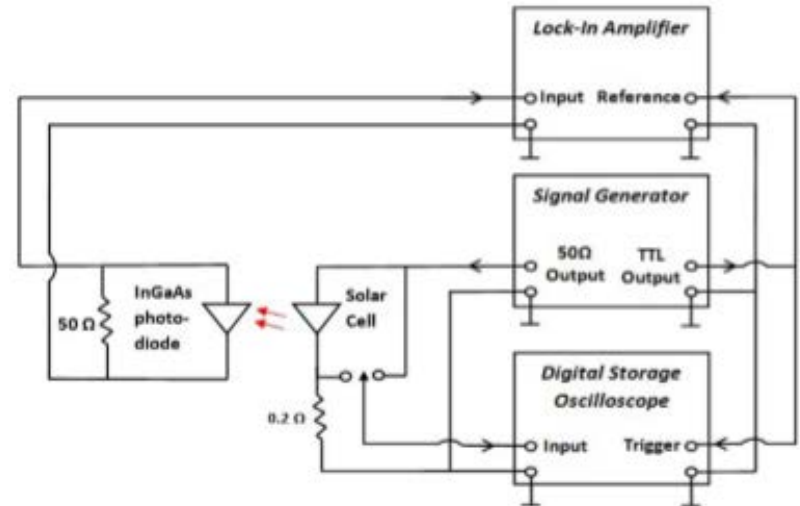

Fig. 2: Schematic of the MEL setup.

Contact(s): Brij Aurora (bmarora@ee.iitb.ac.in) & Maikel van Hest (Maikel.van.hest@nrel.gov)

Publication: S. Khatavkar, Kulsekaran M, C.V. Kannan, V. Kumar, K.L. Narasimhan, P.R. Nair, J. Vasi, M.A. Contreras, M.F.A.M. van Hest, and B.M. Arora, "Measurement of relaxation time of excess carriers in Si and CIGS solar cells by modulated electroluminescence technique," *Phys. Status Solidi A* (2017). DOI: [10.1002/pssa.201700267](https://doi.org/10.1002/pssa.201700267)

